

ASTERION GX are sealed maintenance-free lead-acid batteries with gas recombination system (VRLA). Are manufactured by GEL technology (electrolyte immobilized by the addition of fumed silica). ASTERION GX batteries are less prone to electrolyte drainage and acid stratification.

Accordingly, gel technology offers advantage in applications where long life and deep-cycling are prime requirements, e.g. in motive power for in-plant vehicles or renewable energy systems.

The series is highly reliable and has a service-life up to 15 years.



Battery construction

Element	Positive plate	Negative plate	Case	Lid	Valve	Terminal	Separator	Electrolyte
Material	Lead dioxide	Lead	ABS		Rubber	Copper	Fiberglass	Acid

Specifications

Nominal voltage.....	12 V
Cell.....	6
Design life.....	15 years
Nominal capacity (25°C)	
20 hours rate (1,65 A; 1,75 V/cell).....	33 Ah
10 hours rate (2,98 A; 1,75 V/cell).....	29,8 Ah
5 hours rate (5,55 A; 1,75 V/cell).....	27,75 Ah
Self-discharge.....	3% capacity per month 20°C
Internal resistance (25°C).....	10,3 mΩ

Operating temperature range

Discharge.....	-20+60°C
Charge.....	-10+60°C
Storage.....	-20+60°C
Maximum discharge current (25°C).....	330A (5sec)
Cycle mode (2,35±2,4 V/cell)	
Max.charge current.....	6,5 A
Temperature correction factor.....	30 mV/°C
Standby mode (2,25±2,3 V/cell)	
Temperature correction factor.....	20 mV/°C

Application

- Uninterruptable power supply
- Communication system
- Renewable energy systems
- Total energy system

Performance & characteristics

- Long service life;
- Deep discharge stability;
- Temperature stability characteristics;
- Excluded acid leaks, guaranteed safe operation with other
- There is no gas evolution, enough natural ventilation;
- Operation in any position;
- Maintenance-free. Do not require distillate topping;
- The battery case is made of flame retardant ABS plastic.

Dimensions (±2mm)

Length, mm.....	195
Width, mm.....	130
Height, mm.....	155
Height over terminals, mm.....	168
Weight (±3%), kg.....	11

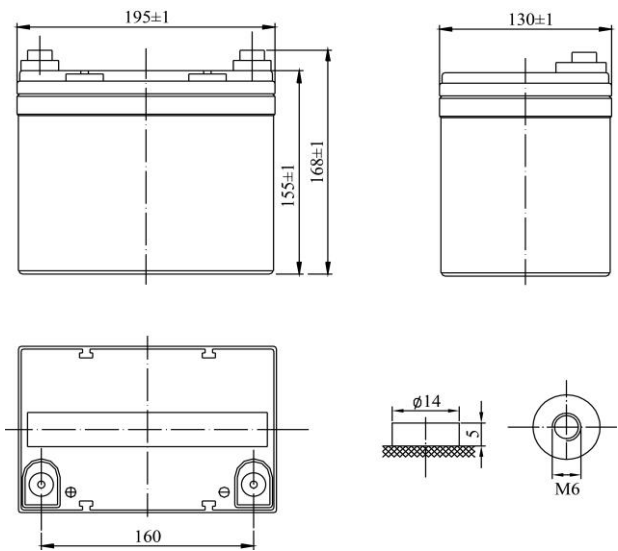

Layout

B



Terminal type

Insert Ø6 mm

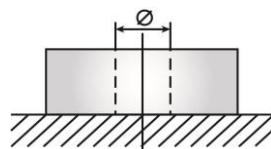

Discharge Constant Current, A (25°C)

V/cell	15 min	30 min	45 min	1 h	3 h	5 h	8 h	10 h	20 h
1,60	60,8	33,4	26,2	22,4	8,90	6,01	3,98	3,27	1,70
1,65	58,1	32,0	25,2	21,6	8,60	5,92	3,89	3,18	1,70
1,70	55,2	30,7	24,2	20,9	8,30	5,72	3,75	3,07	1,70
1,75	52,5	29,1	23,0	19,9	8,03	5,55	3,64	2,98	1,65
1,80	49,4	27,6	21,8	18,8	7,62	5,38	3,52	2,87	1,60

Discharge Constant Power, W/cell (25°C)

V/cell	15 min	30 min	45 min	1 h	3 h	5 h	8 h	10 h	20 h
1,60	111	62,3	48,9	41,9	16,9	11,5	7,54	6,16	3,19
1,65	107	60,0	47,3	40,7	16,4	11,4	7,43	6,05	3,18
1,70	102	57,9	45,8	39,5	15,9	11,1	7,23	5,88	3,16
1,75	97,5	55,3	43,8	37,8	15,5	10,8	7,05	5,73	3,10
1,80	92,3	52,7	41,8	36,1	14,8	10,5	6,85	5,58	3,09

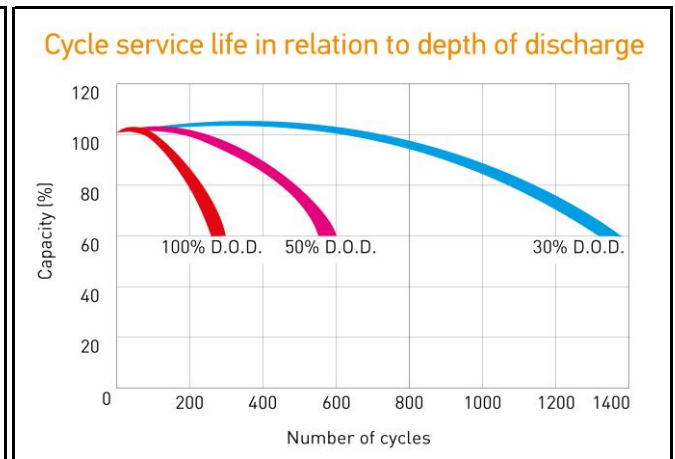
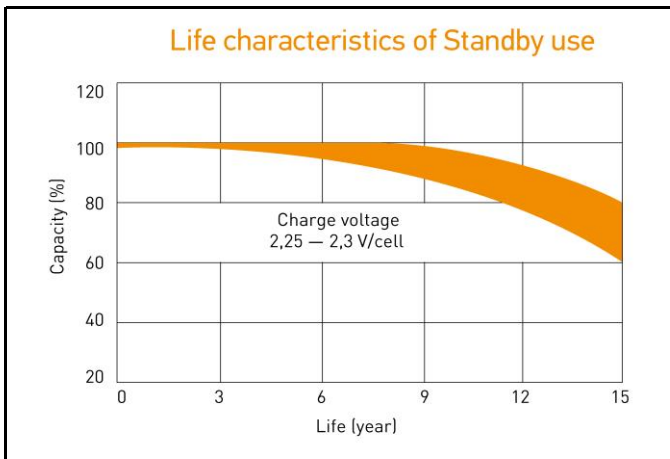
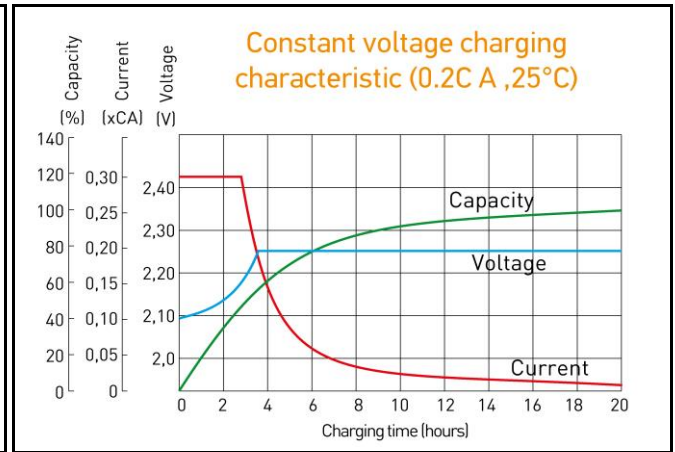
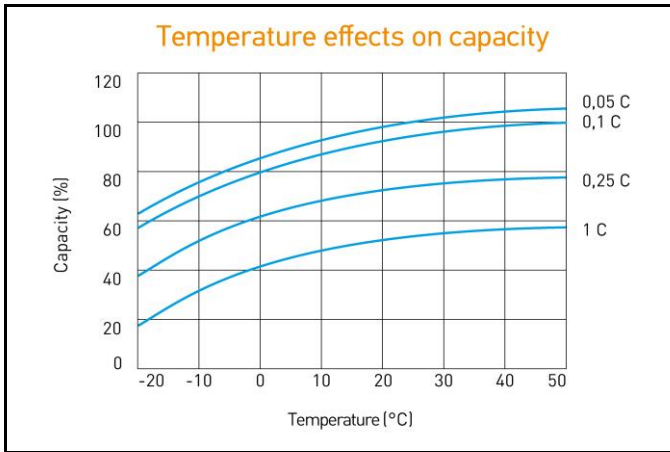

ALL DATA IS SUBJECT TO CHANGE WITHOUT NOTICE