



TECHNICAL PASSPORT

ASTERION RTL LITHIUM-ION BATTERIES

1. INTRODUCTION

The Data Sheet covers scalable ASTERION Xpert Lithium-ion batteries designed to ensure uninterrupted operation of communication and telecommunication systems facilities.

Chemical formula of ASTERION Xpert Lithium-ion batteries is LiFePO_4 . They have an abbreviated designation RTL (Reliable Telecom Lithium) and hereinafter referred to as Asterion RTL batteries.

Asterion RTL batteries comply with the following requirements and standards: IEC 60364-4-41:2005 Part 4-41, IEC 62485-1:2015, IEC 61000.3.2-2009 Sections 5 and 7; IEC 61000-3-3:2008 Section 5, IEC 721-2-1:1982 Section 2, IEC 68-1:1988.

2. INTENDED USE AND CONFIGURATION

Asterion RTL Lithium-ion batteries with rated capacity of 10 to 200 A*h have discharge current up to 1C and are designed to ensure uninterruptible power supply of 48 VDC systems of communication and telecommunication facilities.

Asterion RTL batteries can be scalable when connected in parallel with each other, to increase their total capacity. Serial connection of batteries is not allowed.

An Asterion RTL battery consists of:

- a battery module made of 15 series-connected Lithium-ion cells with voltage of 3.2 VDC, built so as to be mounted in rack 19";
- a Battery Management System (BMS) for cells, used for their balancing and status monitoring;
- a battery operation and charge/discharge status indication and monitoring system.

3. TECHNICAL SPECIFICATION

Specifications of Asterion RTL batteries are provided in table below.

Parameter/battery type (series)	Asterion RTL 10Ah	Asterion RTL 20Ah	Asterion RTL 40Ah	Asterion RTL 50Ah	Asterion RTL 100Ah	Asterion RTL 150Ah	Asterion RTL 200Ah
Cell type	LiFePO ₄						
Number of series-connected cells in the battery	15						
Rated output voltage of the battery, V	48.0						
Number of series-connected batteries in the rack	1	1	1	1	1	1	1
Capacity, A*h	10	20	40	50	100	150	200
Maximum discharge current, A	10	20	40	50	100	100	100
Maximum charging current, A	10	20	40	50	100	100	100
Operating temperature, °C	-20..+60						
Weight, kg	8	14,1	20	24,5	39,5	57,5	73
Overall dimensions(WxDxH), mm	442x285x44	442x285x88	442x430x88	442x440x134,5	442x480x134,5	442x540x190	442x640x222
Maximum number of batteries connected in parallel	≤16						
Connection interfaces	RS232, RS485 (SNMP protocol as an option), two dry contacts						
Service life, charging-discharge cycles	Up to 4,000 at 80 % discharge Up to 3,500 at 90 % discharge						

Standard protection functions of Lithium-ion battery's BMS:

- Load and charging circuit short-circuit monitoring;
- Charging and discharge overcurrent monitoring;
- Battery cell recharge/deep discharge monitoring;
- Battery cell high/low temperature monitoring;
- Current consumption (charging) limitation: 41.0 to 45.0 A at charging of 0.1 C.

In addition to standard functions, Asterion RTL batteries can have additional characteristics and functions according to the customers' requirements:

- an LCD display;
- modular circuit-breaker as the main switch (for capacity of 100 to 200 Ah);
- a heater;
- remote monitoring function;
- anti-theft protection.

4. APPEARANCE

Front panel of an Asterion RTL battery with capacity of 10/20/40/50 Ah, BMS, and components intended for its status indication and monitoring as well as data transmission with other batteries is shown in Fig. 1.

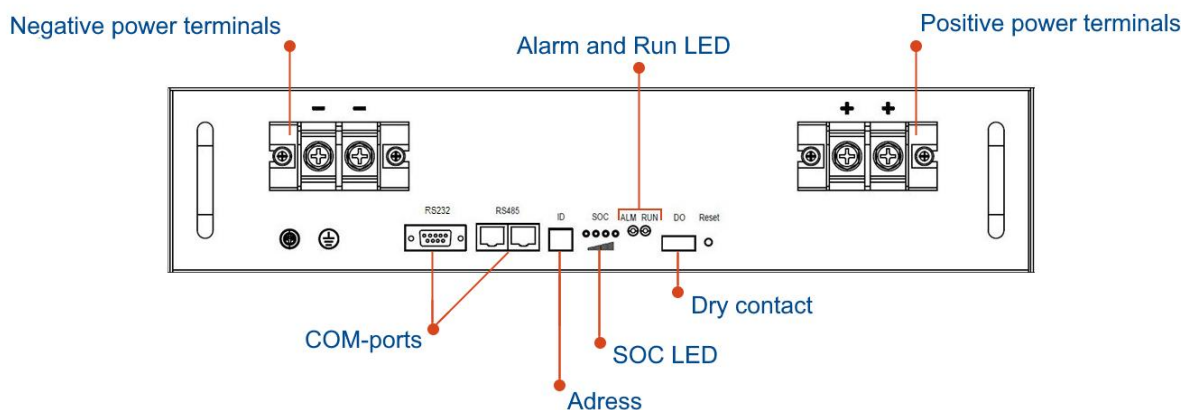

Figure 1. Asterion RTL battery with capacity of 10/20/40/50 Ah

An Asterion RTL battery with capacity of 100/150/200 Ah is shown in Fig. 2.

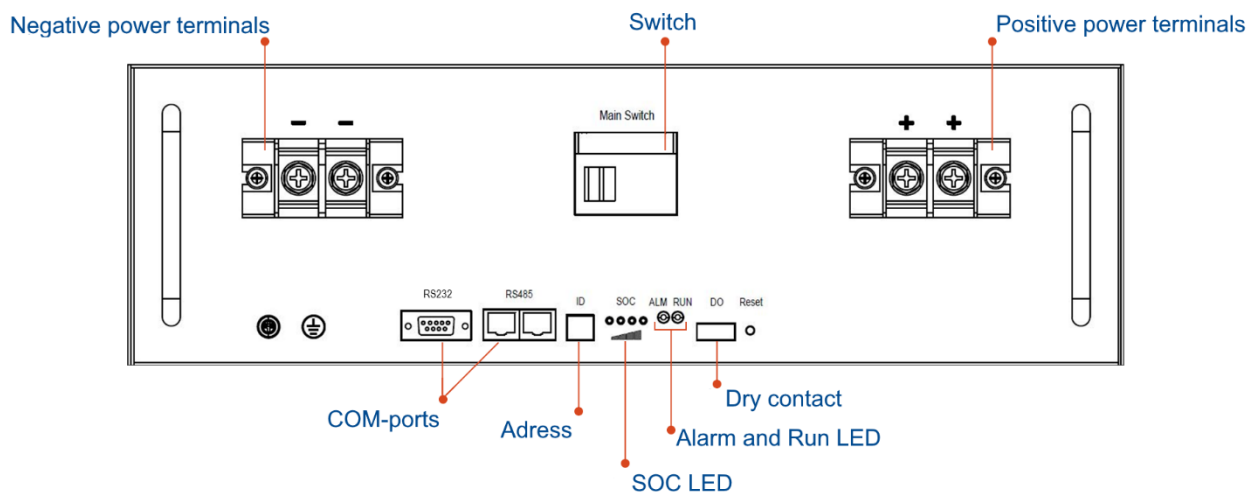

Figure 2. Asterion RTL battery with capacity of 100/150/200 Ah

5. PARALLEL CONNECTION

The battery can be connected in parallel both from pole to pole of each battery, as shown in Fig. 3.1, and to common positive (+) and negative (-) copper buses, as shown in Fig. 3.2.



Figure 3.1

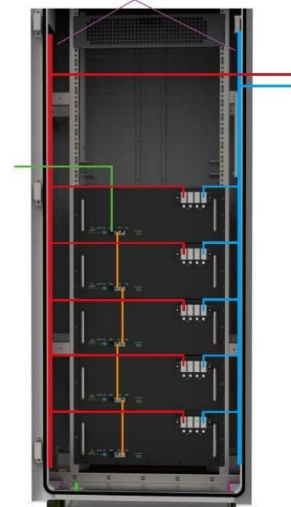

Figure 3.2

6. OPERATION

Asterion RTL batteries shall be discharged with current of 0.1C to 1C.

Asterion RTL batteries shall be charged by the compatible chargers built in communication and telecommunication systems.

Asterion RTL batteries shall be charged with current of 0.5C. The charging current of 1C is allowed, but not in cycling mode.

Asterion RTL batteries are designed for operation under the following conditions:

- Elevation above sea level: up to 2,000 m;
- Ambient temperature: -20 °C (-40 °C when cells are heated) to +60 °C (limits), recommended range of operating temperatures: 0 to +50 °C.

7. LIFE CYCLE, SHELF LIFE AND STORAGE

Service life of Asterion RTL batteries depends on number of discharge/charging cycles and is provided for in specifications (over 3,000 cycles under normal conditions).

An Asterion RTL batteries are not subject to any special preservation. They may be stored for up to 2 years after preliminary charging to 100 % and discharge down to 50 %.

Storage temperature of Asterion RTL batteries is -20 °C to +60 °C.

8. DISPOSAL

After expire of the service life, Asterion RTL batteries shall be subjected to disposal with involvement of specialized services. For advice regarding disposal of Asterion RTL batteries, please, contact their manufacturer or distributor.

It is expressly prohibited to dispose of Asterion RTL batteries with other municipal solid waste, which might result in fire or emission of toxic substances and other irreversible consequences.

WARRANTY

Model: _____

Serial number: _____

Sale Date: _____

Seller: _____

Stamp _____

Seller`s address: _____

Seller`s phone number: _____

1. The warranty period for the Asterion RTL batteries is three years from the date of purchase of the product.
2. If the battery fails through no fault of the purchaser during the warranty period, the seller will repair or replace the inverter at no additional charge.
3. Warranty repair is performed at the service center of the product manufacturer, an organization authorized to accept product quality claims, or the seller. The warranty period is extended for the duration of the repair.
4. The warranty of the set does not cover:
 - mechanical, chemical, thermal and other damage to the battery;
 - failure due to non-compliance with the rules of installation and operation;
 - failures caused by repair or modification of the set by persons not authorized by the manufacturer
5. The warranty does not cover damage caused to other equipment.

Battery received, no mechanical defects. I have no claims to the appearance and completeness. I have read and agree with the warranty obligations.

Purchaser: _____
Full name



ENERGON TÜRKİYE

Phone/fax: + 90 212 951 00 59

E-mail: info@energonturkey.com

asterion-batt.com.tr